

For Boiling/Flashing Liquids at Pressures Up To 2400 PSI @ 100°F (38°C)

Series L10



Reflex
RL-10

Transparent
TL-10

Features

- Recessed Gasket Seat in Chamber and Cover
- Tempered Borosilicate Glass conforming to BS3463, JIS B8211, & DIN 7081
- Wetted Parts conform to NACE MR0175 & MR0103
- All parts listed in ASTM or ASME B31.3
- ABS Certified
- All Gages feature a continuous, one-piece chamber regardless of length

Jerguson Large Chamber Gages are designed to give an accurate liquid level reading of liquids that have a tendency to surge or boil. These gages are highly effective in:

- (1) reducing the boiling effects of entrained gas being released under low pressure,
- (2) eliminating apparent level fluctuations that occur in standard gages (with small chambers) when boiling / flashing vapors try to rise to the surface, and
- (3) applications where the operating temperature is below freezing and high ambient temperatures cause the temperature of the fluid in the gage to exceed the boiling point of the liquid. In applications where the operating temperature is below freezing the gage must be equipped with Non-Frost Extensions.

Jerguson Large Chamber Gages are available in reflex or transparent design. The liquid chamber is constructed of heavy tubing, carefully slotted and machined to provide plane seats for the gaskets and glass assemblies. Standard covers are carbon steel secured with specially designed carbon steel bolts.

PRESSURE / TEMPERATURE RATINGS, PSI

Temperature		RL-10 REFLEX GAGE								
		Glass Size								
°F	°C	1	2	3	4	5	6	7	8	9
100	38	2400	2250	2100	1940	1800	1640	1500	1340	1200
200	93	2220	2090	1950	1810	1670	1540	1400	1260	1130
300	149	2050	1920	1800	1680	1540	1430	1300	1180	1060
400	204	1860	1750	1640	1530	1420	1320	1200	1100	1000
500	260	1690	1600	1500	1400	1300	1210	1110	1010	920
600	316	1520	1430	1350	1260	1180	1100	1010	920	850
For temperatures above 600°F (316°C) Aluminosilicate Glass <i>must</i> be used										
700	371	1340	1270	1200	1130	1060	990	920	850	780
800	427	1170	1110	1060	1000	940	880	830	770	710

Not recommended for steam service.

Temperature		TL-10 TRANSPARENT GAGE								
		Glass Size								
°F	°C	1	2	3	4	5	6	7	8	9
100	38	1200	1110	1020	930	850	760	680	590	500
200	93	1080	1000	920	840	760	680	600	530	450
300	149	960	890	830	750	680	620	540	470	400
400	204	850	790	720	670	600	540	480	420	360
500	260	730	680	630	570	520	470	420	360	310
600	316	620	570	530	480	440	400	360	310	270
For temperatures above 600°F (316°C) Aluminosilicate Glass <i>must</i> be used										
700	371	500	470	430	400	360	330	290	260	220
800	427	390	360	340	310	290	260	230	210	180

Not recommended for steam service.

PRESSURE / TEMPERATURE RATINGS, BarG

Temperature		RL-10 REFLEX GAGE								
		Glass Size								
°F	°C	1	2	3	4	5	6	7	8	9
100	38	165.5	155.1	144.8	133.8	124.1	113.1	103.4	92.4	82.7
200	93	153.1	144.1	134.4	124.8	115.1	106.2	96.5	86.9	77.9
300	149	141.3	132.4	124.1	115.8	106.2	98.6	89.6	81.4	73.1
400	204	128.2	120.7	113.1	105.5	97.9	91.0	82.7	75.8	68.9
500	260	116.5	110.3	103.4	96.5	89.6	83.4	76.5	69.6	63.4
600	316	104.8	98.6	93.1	86.9	81.4	75.8	69.6	63.4	58.6
For temperatures above 600°F (316°C) Aluminosilicate Glass <i>must</i> be used										
700	371	92.4	87.6	82.7	77.9	73.1	68.3	63.4	58.6	53.8
800	427	80.7	76.5	73.1	68.9	64.8	60.7	57.2	53.1	49.0

Not recommended for steam service.

Temperature		TL-10 TRANSPARENT GAGE								
		Glass Size								
°F	°C	1	2	3	4	5	6	7	8	9
100	38	82.7	76.5	70.3	64.1	58.6	52.4	46.9	40.7	34.5
200	93	74.5	68.9	63.4	57.9	52.4	46.9	41.4	36.5	31.0
300	149	66.2	61.4	57.2	51.7	46.9	42.7	37.2	32.4	27.6
400	204	58.6	54.5	49.6	46.2	41.4	37.2	33.1	29.0	24.8
500	260	50.3	46.9	43.4	39.3	35.9	32.4	29.0	24.8	21.4
600	316	42.7	39.3	36.5	33.1	30.3	27.6	24.8	21.4	18.6
For temperatures above 600°F (316°C) Aluminosilicate Glass <i>must</i> be used										
700	371	34.5	32.4	29.6	27.6	24.8	22.8	20.0	17.9	15.2
800	427	26.9	24.8	23.4	21.4	20.0	17.9	15.9	14.5	12.4

Not recommended for steam service.

TEST PRESSURE: All gages are hydrostatically tested by Jerguson prior to shipment @ 1 1/2 times the design pressure rating at 100°F (38°C).

Liquid Level Gages

Series RL-10 Reflex & Series TL-10 Transparent

Size No.	Visible Range		Overall Length		RL-10 Reflex Approximate Weight		TL-10 Transparent Approximate Weight	
	in	mm	in	mm	lbs.	Kgs	lbs.	Kgs
11	3.750	95	6.188	157	11	5.0	14	6.4
12	4.750	121	7.188	183	13	5.9	17	7.7
13	5.750	146	8.188	208	15	6.8	19	8.6
14	6.750	171	9.188	233	17	7.7	21	9.5
15	7.875	200	10.313	262	18	8.2	23	10.5
16	9.125	232	11.563	294	20	9.1	26	11.8
17	10.250	260	12.688	322	22	10.0	29	13.2
18	11.875	302	14.313	364	25	11.4	32	14.5
19	12.625	321	15.063	383	26	11.8	34	15.5
23	13.000	330	15.438	392	27	12.3	36	16.4
24	15.000	381	17.438	443	31	14.1	40	18.2
25	17.250	438	19.688	500	34	15.5	45	20.5
26	19.750	502	22.188	564	39	17.7	50	22.7
27	22.000	559	24.438	621	43	19.5	55	25
28	25.250	641	27.688	703	48	21.8	62	28.2
29	26.750	679	29.188	741	51	23.2	65	29.5
36	30.375	772	32.813	833	57	25.9	74	33.6
37	33.750	857	36.188	919	63	28.6	82	37.3
38	38.625	981	41.063	1043	71	32.3	92	41.8
39	40.875	1038	43.313	1100	75	34.1	97	44.1
47	45.500	1156	47.938	1218	84	38.2	108	49.1
48	52.000	1321	54.438	1383	95	43.2	122	55.5
49	55.000	1397	57.438	1459	99	45.0	129	58.6
57	57.250	1454	59.688	1516	104	47.3	135	61.4
58	65.375	1661	67.813	1722	118	53.6	153	69.5
59	69.125	1756	71.563	1818	123	55.9	161	73.2
68	78.750	2000	81.188	2062	141	64.1	183	83.2
69	83.250	2115	85.688	2176	148	67.3	192	87.3
78	92.125	2340	94.563	2402	164	74.5	213	96.8
79	97.375	2473	99.813	2535	172	78.2	224	101.8
88	105.500	2680	107.938	2742	187	85.0	243	110.5
89	111.500	2832	113.938	2894	196	89.1	256	116.4

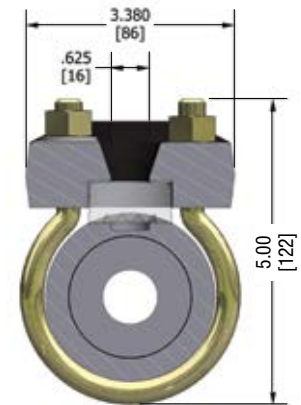

Series RL-10 Reflex

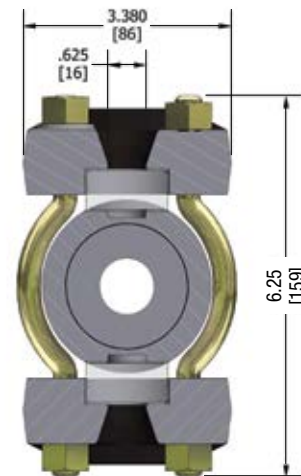

Series TL-10 Transparent



CE models available



Specifications (See page 3 for Specifying Information)

LENGTHS

Gage sections are available in 9 standard glass sizes. Longer sizes are constructed with multiple vision slots in a continuous solid tube chamber.

CONNECTIONS

Standard connections are at top and bottom and are 1/2" or 3/4" NPT female. Up to 2" NPT or socket weld end, side, or back connections are also available.

LIQUID CHAMBER

Heavy wall tubing, 2" inside diameter. Gasket seats are machined on the face of the chamber and assembly torques are designed to prevent sidewise movement of gasket.

COVERS

Forged carbon steel non-shrouded covers are standard with optional materials available. The cushion gasket surface is recessed on all covers.

BOLTS & NUTS

Steel fasteners, heat treated for strength; A193 B7 bolts / A194 2H nuts. NACE options include A193 B7M bolts / A194 2HM nuts (Transparent only) and A193 B8M bolts / A194 8M nuts (316 Stainless Steel).

GLASS

Tempered Borosilicate is used to 600°F (316°C). Aluminosilicate is used to 800°F (427°C). Transparent glass may be protected from corrosive media with mica or Neoflon PCTFE shields.

GASKETS

Standard gaskets are precision die cut in proprietary Jerguson® dies.

FINISH

All carbon steel parts are finish coated prior to assembly with Jerguson Protective FP-16. Optional coatings such as FP-11 offshore available.

VALVES

Use of Jerguson gage valves is strongly recommended. Standard features include safety ballchecks which help prevent loss of product and physical injury in the event of a catastrophic failure.

Glass Types & Sizes

Glass Materials

- Borosilicate
 - Up to 600°F (316°C)
 - Up to 300 WSP
 - Over 300 WSP, Mica Protected Transparent Glass Only
- HP Borosilicate
 - Up to 600°F (316°C)
 - Higher Tolerances
- Aluminosilicate
 - Up to 800°F (426°C)

Glass Sizes – Industry Standard 34mm
 Sizes 1 thru 9 (All models except 300L)

Size	Length	Typical Visible Range
1	4-1/2" (115mm)	3-3/4" (95mm)
2	5-1/2" (140mm)	4-3/4" (121mm)
3	6-1/2" (165mm)	5-3/4" (146mm)
4	7-1/2" (190mm)	6-3/4" (171mm)
5	8-5/8" (220mm)	7-7/8" (200mm)
6	9-7/8" (250mm)	9-1/8" (232mm)
7	11" (280mm)	10-1/4" (260mm)
8	12-5/8" (320mm)	11-7/8" (302mm)
9	13-3/8" (340mm)	12-5/8" (321mm)



Glass Sizes – Jerguson 25mm
 Sizes 11 thru 20 (Series 300L - Obsolete 5 & 12)

Size	Length	Typical Visible Range
11	11" (280mm)	10-1/4" (260mm)
12	12" (305mm)	11-1/4" (286mm)
13	13" (330mm)	12-1/4" (311mm)
15	15" (381mm)	14-1/4" (362mm)
18	18" (457mm)	17-1/4" (438mm)
20	20" (508mm)	19-1/4" (489mm)

Specification

Materials of Construction

- Borosilicate Glass
- Gaskets
 - IFG® -5500 Standard (Seal/Cushion)
 - Graphite, with .002" (.05mm) stainless steel reinforcement layer
 - Teflon®
 - Other Materials Available

Chamber

- Carbon Steel
 - To -20°F (-28°C)
- Low Temp Carbon Steel
 - To -50°F (-45°C)
 - Charpy Impact Tested
 - B7M Bolts / 2HM Nuts
- Stainless Steel
 - To -325°F (-198°C)
 - Dual Rated 316/316L
- All Acceptable for NACE Service

Shields

Shields are used to protect the glass from chemical attack. Two shields are available: Mica and PCTFE.

Mica: Mica shields are used to protect the glass from corrosion in high pressure steam (over 300WSP) and caustic applications (pH >11).
 PCTFE: PCTFE shields (formerly known as Kel-F®) are primarily used in Hydrofluoric Acid service. Note that the PCTFE shield also serves as the sealing gasket; no additional sealing gasket is required.



Gage Code for Jerguson Gages

- Glass Size Series 300L: 11, 12, 13, 15, 18, 20
 Other Series: 1 thru 9
- Special Features
 M = Mica Shield
 K = PCTFE (Kel-F) Shield
 F = Non-frosting
 H = External Heating
 E = Electrical Heating
 T = Internal Heating
 CH = Close Hook-up (Side or Back Conns.)
 W = Weld Pad
 IW = Isolable Weld Pad

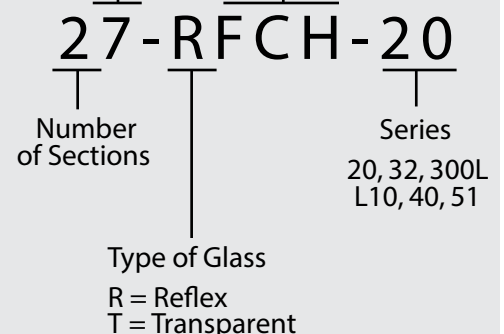

Gasket Materials— Standard Offering

Material	Min. Temperature	Max. Temperature	Rating Factor
Garlock IFG-5500	-40°F (-40°C)	550°F (288°C)	100%
25% Glass Filled TFE	-328°F (-200°C)	500°F (260°C)	100%
Grafoil	-400°F (-240°C)	800°F (427°C)	100%
PCTFE (Kel-F) Shield	-400°F (-240°C)	302°F (150°C)	50%